

# Rolling Bearing Failure Analysis

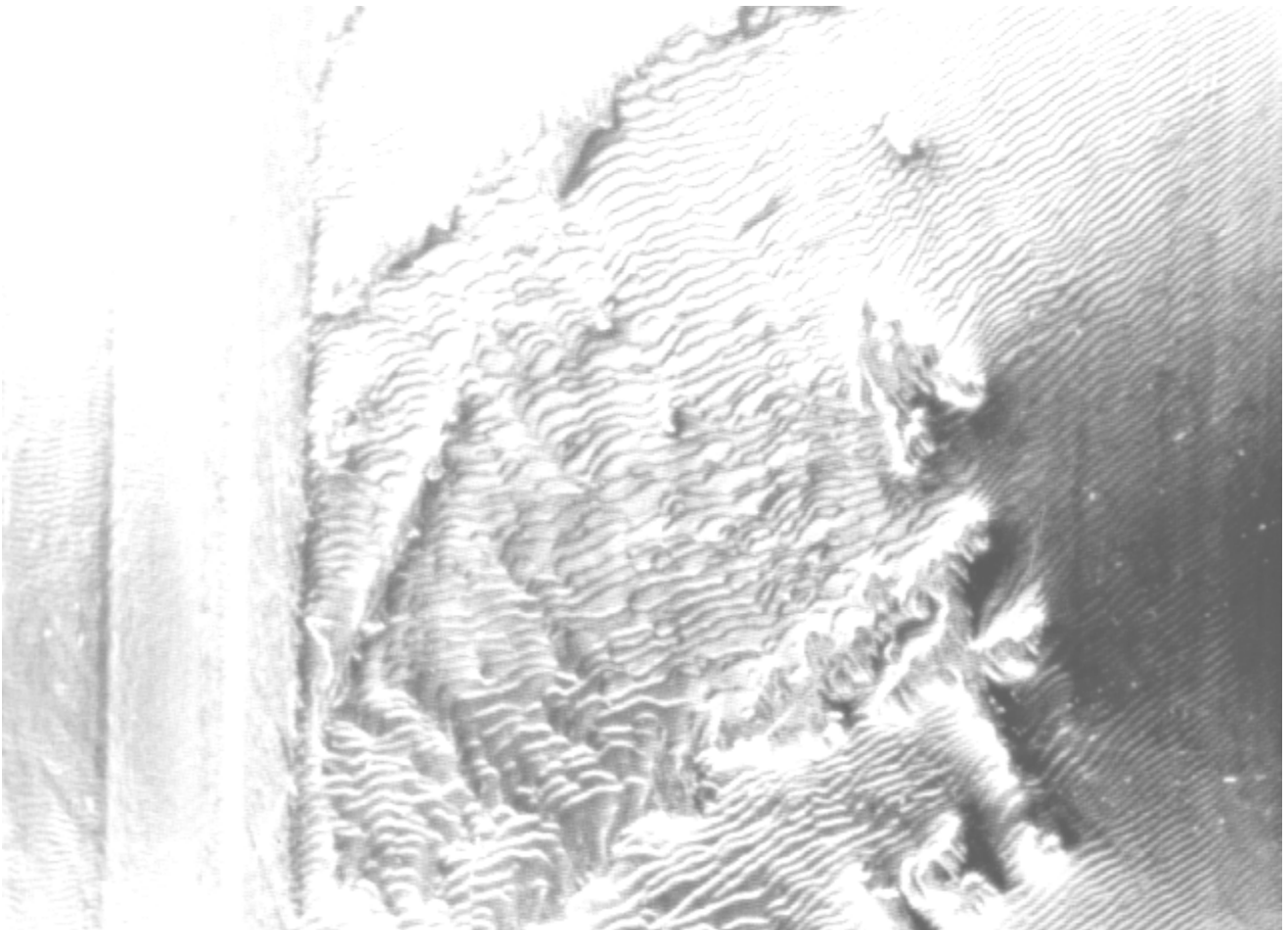



# Contents

<b>1. BEARING FAILURE ANALYSIS</b>	<b>3</b>
<b>1.1 DETERMINATION OF OPERATING DATA</b>	<b>3</b>
<b>1.2 LUBRICANT SAMPLING</b>	<b>4</b>
<b>1.3 INSPECTION OF THE BEARING ENVIRONMENT</b>	<b>4</b>
<b>1.4 ASSESSMENT OF BEARING IN MOUNTED CONDITION</b>	<b>5</b>
<b>1.5 DISMOUNTING THE DAMAGED BEARING</b>	<b>5</b>
<b>1.6 ASSESSMENT OF THE COMPLETE BEARING</b>	<b>5</b>
<b>1.7 ASSESSMENT OF BEARING COMPONENTS</b>	<b>6</b>
<b>1.8 ROLLING BEARING DAMAGE SYMPTOMS AND THEIR CAUSES</b>	<b>7</b>
<b>2. ROLLING BEARING DAMAGE</b>	<b>9</b>
<b>2.1 DAMAGE RELATING TO BEARING RINGS</b>	<b>9</b>
2.1.1 FRETTING CORROSION	10
2.1.2 TRACKS IN THE CASE OF INADEQUATE LUBRICATION	11
2.1.3 TRACKS IN THE CASE OF CONTAMINATION IN BEARING OR LUBRICANT	12
2.1.4 UNUSUAL TRACKS WITH DETRIMENTAL RADIAL PRELOAD	13
2.1.5 TRACKS WITH OVAL DEFORMATION	14
2.1.6 DETRIMENTAL AXIAL PRE-LOAD	15
2.1.7 TRACKS WITH MISALIGNMENT	16
2.1.8 FATIGUE OF ROLLING BEARINGS DUE TO MISALIGNMENT	17
2.1.9 FATIGUE AS A RESULT OF POOR LUBRICATION	18
2.1.10 CORROSION	19
2.1.11 FALSE BRINELLING	20
2.1.12 PASSAGE OF ELECTRIC CURRENT	21
2.1.13 RING FRACTURES	22
2.1.14 SLIPPAGE TRACKS	24
2.1.15 SCORE MARKS	25
2.1.16 DAMAGE DUE TO OVERHEATING	26
2.1.17 ASSESSMENT OF LIP CONTACT	27
<b>2.2 DAMAGE RELATING TO BEARING CAGES</b>	<b>28</b>
2.2.1 CAGE WEAR DUE TO STARVED LUBRICATION AND CONTAMINATION	28
2.2.2 WEAR DUE TO EXCESS SPEED	28
2.2.3 WEAR DUE TO ROLLER SKEWING	29
2.2.4 WEAR IN BALL BEARING CAGES DUE TO TILTING	30
2.2.5 CAGE FRACTURE	31
2.2.6 DAMAGE DUE TO INCORRECT MOUNTING	31

# Rolling Bearing Failure Analysis

---

## 1. Bearing Failure Analysis

The purpose of inspecting damaged bearings and their mating parts is to determine the probable causes of the damage and to avoid any future failures. A systematic procedure should be implemented to assist in resolving bearing failures. The following measures should be considered:

- ✓ Obtain or determine operating data. e.g. loads, speed etc.
- ✓ Extract lubricant samples from inside and around the bearing
- ✓ Check bearing and surrounding environment
- ✓ Assess bearing in mounted position
- ✓ Mark orientation of bearing in the mounting position
- ✓ Dismount the bearing using the correct techniques
- ✓ Mark and identify the bearings and parts
- ✓ Assess the complete bearing

### 1.1 Determination of operating data

When inspecting damaged rolling bearings, not only the bearing itself is examined but also the surrounding conditions and the application. If possible, drawings and pictures should also be considered for the assessment process. The following details would be required:

- ✓ Application: machine, bearing location, service life, how many similar machines and how many failures in these machines
- ✓ Bearing constructions: locating bearing, floating bearing arrangement, adjusted bearings (adjusted with spacers, nut, covers, springs or shims)
- ✓ Speed: constant, alternating (inner ring and outer ring), acceleration or deceleration
- ✓ Load: axial, radial, combined, tilting movement, constant, changing (collective), oscillating (acceleration, oscillation, amplitude), centrifugal force, point load, circumferential load (which ring is running?)
- ✓ Mating parts: shaft & housing (fits), fastening parts (e.g. type of locknut, bolts etc.)
- ✓ Environmental conditions: external heat, cooling, special media (e.g. oxygen, vacuum, radiation), stationary vibrations, dust, dirt, dampness, corrosive agents, electric or magnetic fields
- ✓ Lubrication: lubricant, lubricant quantity, lubricant supply, re-lubrication interval, date of last lubrication interval/ last oil change
- ✓ Sealing type & design: contact, non-contact
- ✓ History of damaged bearing: first mounting or replacement bearing, changes in bearing location, evaluate data and records from bearing monitoring devices, if available.

## Rolling Bearing Failure Analysis

---

### 1.2 Lubricant sampling

When assessing damaged bearings, the condition of the lubricants should also be evaluated as part of the assessment process. The following points relate to the evaluation of the lubricants.

#### *Grease lubrication:*

- ✓ Documentation of grease distribution and colour in the bearing environment
- ✓ Clearly identify all samples when taken from different places in the bearing and housing

#### *Oil lubrication:*

- ✓ Remove samples from the oil flow near the bearing or from the middle of the oil reservoir
- ✓ Extract samples directly after operation to obtain the typical distribution of foreign matter
- ✓ Do not remove samples from the bottom or directly before the filters (wrong concentration of particles)
- ✓ Filter residue should also be kept for inspection (indicates history prior to damage)

#### *General Information:*

- ✓ How often has the bearing been re-lubricated or had the oil changed? When was either last carried out?
- ✓ Check oil or grease for any small flakes or pieces of bearing or other components
- ✓ Use clean glass sample bottles
- ✓ There should be enough room left in the sample bottles for stirring the oil sample in the laboratory
- ✓ The analysis of the samples may take place at the customer's or at an external lubricant laboratory.
- ✓ Points of interest are generally the degree of contamination and its type (sand, steel, soft little parts, water, cooling liquid) as well as analysis of the lubricity (e.g. ageing, consolidation, colour, share of additives)

### 1.3 Inspection of the bearing environment

- ✓ Could have the surrounding parts made contact with the bearing parts anywhere?
- ✓ Any other parts damaged near the bearing (consequential or primary damage)?
- ✓ Cleanliness inside and around the bearings & seals (any foreign matter in the bearing space?)
- ✓ Loose fastening devices and parts (was the bearing forced to deform? Are the bolts loose?)

## Rolling Bearing Failure Analysis

---

### 1.4 Assessment of bearing in mounted condition

- ✓ Are there any ruptured or chipped areas?
- ✓ Are any of the seals damaged, particularly deformed or hardened?
- ✓ Has the bearing suffered any indentations on the visible areas?
- ✓ Consider the effect of the fits. Does the bearing run easily or tightly in mounted condition?

### 1.5 Dismounting the damaged bearing

Care should be taken to minimise any further damage to the bearings during dismounting. Any additional damage could alter, change or destroy the existing damage pattern or clues.

The following procedure should be observed if possible:

- ✓ Prevent any further damage to the damage areas inside the bearing
- ✓ Do not apply dismounting force via the rolling elements
- ✓ High dismounting force could be a clue
- ✓ Do not open sealed bearings
- ✓ Do not use cutting torches unnecessarily
- ✓ Do not destroy or damage any heat-sensitive parts, such as lubricant, seal, cage
- ✓ Mark bearings (mounting location, mounted position or direction)

### 1.6 Assessment of the complete bearing

When assessing damaged bearings the lubricant should either remain in the bearing or samples taken for possible analysis.

The following should be checked:

- ✓ General condition (cleanliness of bearing and condition of fitting surfaces, i.e. traces of mounting, fretting corrosion, ring fractures, dimensional accuracy, seizing marks, discoloration)
- ✓ Condition of seals and dust shields. Photograph or describe of the extent of escaped grease
- ✓ Condition of cage
- ✓ Manual rotation test (indication of contamination, damage or preload)
- ✓ Measure the bearing clearance (displaceability of rings in radial and axial direction), whereby bearings are loaded equally and rotated.

## Rolling Bearing Failure Analysis

---

### 1.7 Assessment of bearing components

- ✓ Assessment of bearing seating areas (axial mating surfaces, inner ring bore, outer ring outside diameter)
- ✓ Raceways
- ✓ Lips
- ✓ Sealing seat surface/ contact surface
- ✓ Rolling elements (outside diameter and face in the case of rollers)
- ✓ Cages
- ✓ Seals

## Rolling Bearing Failure Analysis

### 1.8 Rolling bearing damage symptoms and their causes

Table 1

Symptom	Damaged area of the bearing	Typical causes of rolling bearing damage									
						Mounting					
	Seats	Rolling contact area	Lip and roller face areas	Cage	Sealing	Incorrect mounting procedure or tools	Dirt	Fit too tight, to much preload	Fit too loose, too little preload	Poor support of rings	Misalignment of shaft deflection
a) Unusual running behaviour											
Uneven running						X	X		X		
Unusual noise						X	X	X	X	X	X
Disturbed temperature behaviour								X			X
b) Appearance of dismounted bearing parts											
1. Foreign particle indentations		X					X				
2. Fatigue		X				X	X	X		X	X
3. Stationary vibration marks		X									
4. Molten dents and flutes		X									
5. Skidding		X							X		
6. Rolling element indentations, scuffing		X	X			X					
7. Seizing marks		X	X	X							
8. Wear		X	X	X	X		X				
9. Corrosion		X	X	X	X						
10. Overheating damage	X	X	X	X	X			X			
11. Fractures	X	X	X	X		X		X		X	
12. Fretting corrosion (false brinelling)	X								X	X	



## Rolling Bearing Failure Analysis

### Rolling bearing damage symptoms and their causes (Continued)

Table 2

Symptom	Damaged area of the bearing	Typical causes of rolling bearing damage								
	Operational Stress			Environmental influence				Lubrication		
	Load to high or to low	Vibrations	High Speeds	Dust, dirt	Aggressive media, water	External Heat	Current passage	Unsuitable lubricant	Insufficient lubricant	Excess lubricant
a) Unusual running behaviour										
Uneven running		X		X	X		X	X		
Unusual noise	X	X		X	X		X	X	X	
Disturbed temperature behaviour	X		X			X		X	X	X
b) Appearance of dismounted bearing parts										
1. Foreign particle indentations				X						
2. Fatigue	X			X		X		X	X	
3. Stationary vibration marks		X								
4. Molten dents and flutes							X			
5. Skidding	X								X	
6. Rolling element indentations, scuffing	X									
7. Seizing marks	X		X					X	X	
8. Wear				X				X	X	
9. Corrosion					X			X		
10. Overheating damage			X			X		X	X	X
11. Fractures										
12. Fretting corrosion (false brinelling)		X								

## **Rolling Bearing Failure Analysis**

---

### **2. Rolling Bearing Damage**

After analysing the all the data and the physical damage to the bearing and surrounding parts the next step is to determine the reason/s for the failure. In this section, examples of damaged bearings (pictures and illustrations) and their symptoms, causes and possible remedies are provided.

#### **2.1 Damage relating to bearing rings**

Whether the tracking patterns on either the inner or outer ring raceways are to be considered normal or unusual, would depend upon on each individual application. The tracking patterns and damage on the raceways may have been caused by various problems. The following symptoms, causes and remedies maybe of assistance in determining the cause to the failure.

## Rolling Bearing Failure Analysis

### 2.1.1 Fretting corrosion

#### Symptoms:

- ✓ Brownish-black spots on the seats
- ✓ Wear at fitting surfaces
- ✓ Fatigue fracture possible in the case of rotating parts (usually the shaft)
- ✓ Disturbance of floating bearing function possible in the case of stationary parts (usually the housing)

#### Causes:

- ✓ Micro-motion between fitted parts where fits are too loose in relation to the acting forces, but no creeping of rings
- ✓ Form disturbance of fitting surfaces
- ✓ Shaft deflection, housing deformation
- ✓ Incorrect fit selection and surface finishes for the application

#### Possible remedies:

- ✓ Provide the correct fit and surface finish for each bearing ring
- ✓ Use fit selections that provide the best support of the bearing
- ✓ Make shaft & housing designs more rigid
- ✓ Surface coat bearing seats

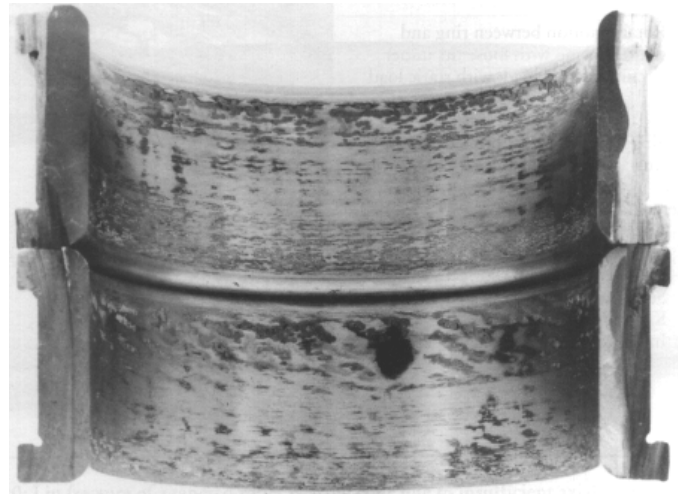

Figure 1: Fretting corrosion in bore of a cylindrical roller bearing inner ring with seat too loose



Figure 2: Fretting corrosion reveals the size of the load zone at the stationary outer ring

## Rolling Bearing Failure Analysis

### 2.1.2 Tracks in the case of inadequate lubrication

#### Symptoms:

Dull roughened tracking patterns arise from poor lubrication conditions. The thinner the lubricating film the greater the influence on the surface. When a specific load is high in the contact areas, the tracks are bright, pressure-polished and frequently shiny and are a clear contrast to the cycled part of the raceways.

#### Causes:

- ✓ Insufficient lubrication (type & quantity etc.)
- ✓ The viscosity of the lubricant is insufficient for the operating temperature and speed

#### Possible Remedies:

- ✓ Improve lubricant supply
- ✓ Change lubricant viscosity to suit operating conditions
- ✓ Use approved lubricants with suitable additives

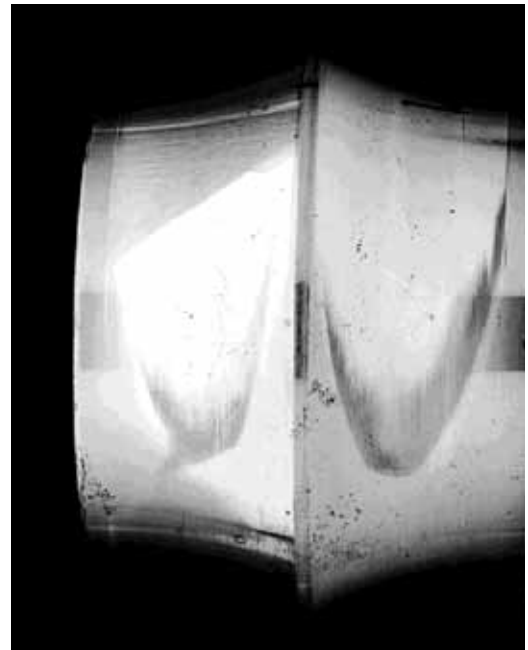

*Figure 3 Spherical roller bearing inner ring with tracks due to inadequate lubrication*

## Rolling Bearing Failure Analysis

### 2.1.3 Tracks in the case of contamination in bearing or lubricant

Symptoms:

Symptoms of contamination:

- ✓ Indentations as a result of foreign particles being cycled on the raceway
- ✓ Fatigue resulting from the cycling of foreign particles
- ✓ Evidence of liquid contamination:
- ✓ Water can be taken up in small amounts by the lubricant – degrades the effect of lubrication
- ✓ In case of large amounts of moisture in the bearing dull tracks arise
- ✓ Pressure-polished tracks with fatigue damage results from corrosion or high load

Causes:

- ✓ Inadequate sealing
- ✓ Mounting conditions not clean
- ✓ Production residues, e.g. foundry sand
- ✓ Temperature differences (condensation of water)
- ✓ Dirty oil

Possible remedies:

- ✓ Improve sealing constructively
- ✓ Clean mounting and well washed mating parts, coat if necessary
- ✓ Clean and rinse the entire oil system before commencing operation



*Figure 4 Deep groove ball bearing with tracks due to contamination in bearing or lubrication*

## Rolling Bearing Failure Analysis

### 2.1.4 Unusual tracks with detrimental radial preload

Symptoms:

- ✓ Circumferential tracks appear on both rings in the case of detrimental radial preload.
- ✓ Running hot

Causes:

- ✓ Fit interference at shaft/ housing too large
- ✓ Excessive temperature difference between inner and outer ring
- ✓ Bearing clearance too small

Possible remedies:

- ✓ Check fit and form accuracy of mating parts
- ✓ Change clearance to suit operating conditions

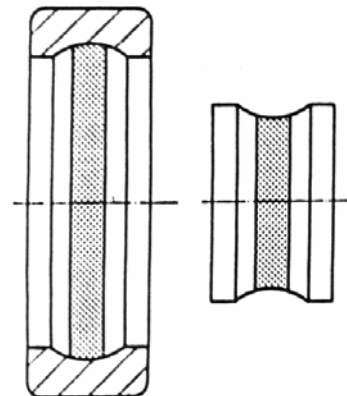

Figure 5 Deep groove ball bearing under detrimental radial pre-load

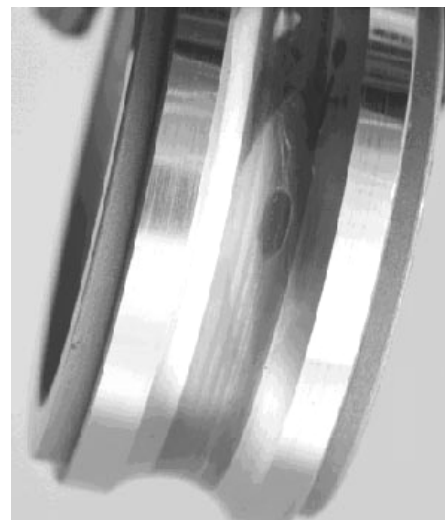

Figure 6: Deep groove ball bearing with inner ring tracking

## Rolling Bearing Failure Analysis

### 2.1.5 Tracks with oval deformation

Symptoms:

- ✓ Separate tracking patterns develop on the circumference of the stationary ring

Causes:

- ✓ Oval housing or shaft
- ✓ Poor housing rigidity and support or high interference fits on the outer ring
- ✓ Storing bearings in the vertical position

Possible remedies:

- ✓ Check fit and form accuracy of mating parts
- ✓ Change assembly and operating conditions
- ✓ Store bearings according to manufacturer's specification

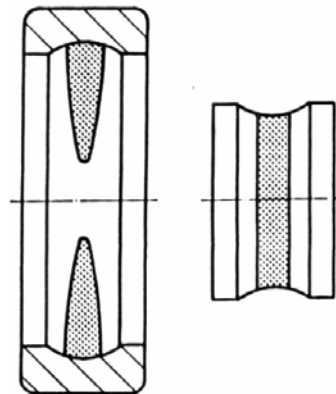

*Figure 7 Oval deformation of a deep groove ball bearing due to oval shaft or housing*

## Rolling Bearing Failure Analysis

### 2.1.6 Detrimental axial pre-load

Symptoms:

- ✓ Only the locating bearing of a locating-floating bearing arrangement may have distinctive tracks.
- ✓ At the most, a slight axial load share should be detected on the floating bearing.

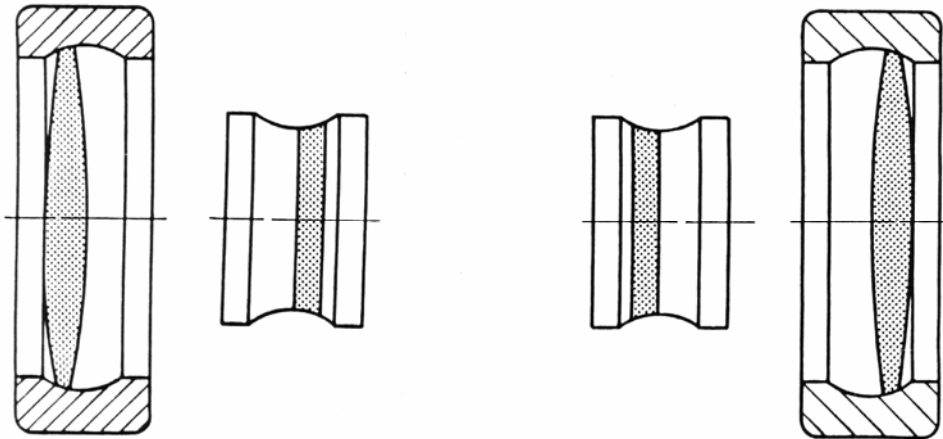

Figure 8: Running Tracks of a similar bearing arrangement under detrimental pre-load

Causes:

- ✓ Disturbed floating bearing function (wrong fit, radial-acting heat expansion, tilting, fretting corrosion)
- ✓ Unexpectedly high axial-loading

Possible remedies:

- ✓ Check fits and form accuracy of mating parts
- ✓ Change assembly and operating conditions
- ✓ Use cylindrical roller bearing N, NU, NJ to allow linear expansion of the shaft when permissible.



## Rolling Bearing Failure Analysis

### 2.1.7 Tracks with misalignment

Symptoms:

- ✓ Tracking pattern of the stationary ring does not run parallel with the raceway

Causes:

- ✓ Shaft deflection
- ✓ Poorly aligned housing halves or plummer block housings
- ✓ Out-of-square abutment surfaces
- ✓ Dirt between abutment surfaces and bearing rings during mounting
- ✓ Bearing clearance is too high in combination with moment load

Possible remedies:

- ✓ Observe mounting specifications regarding permissible tilting
- ✓ Ensure cleanliness during mounting
- ✓ Set suitable bearing clearance

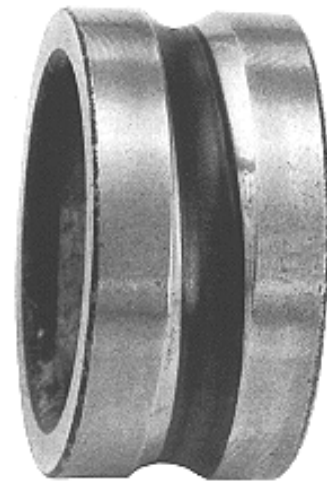
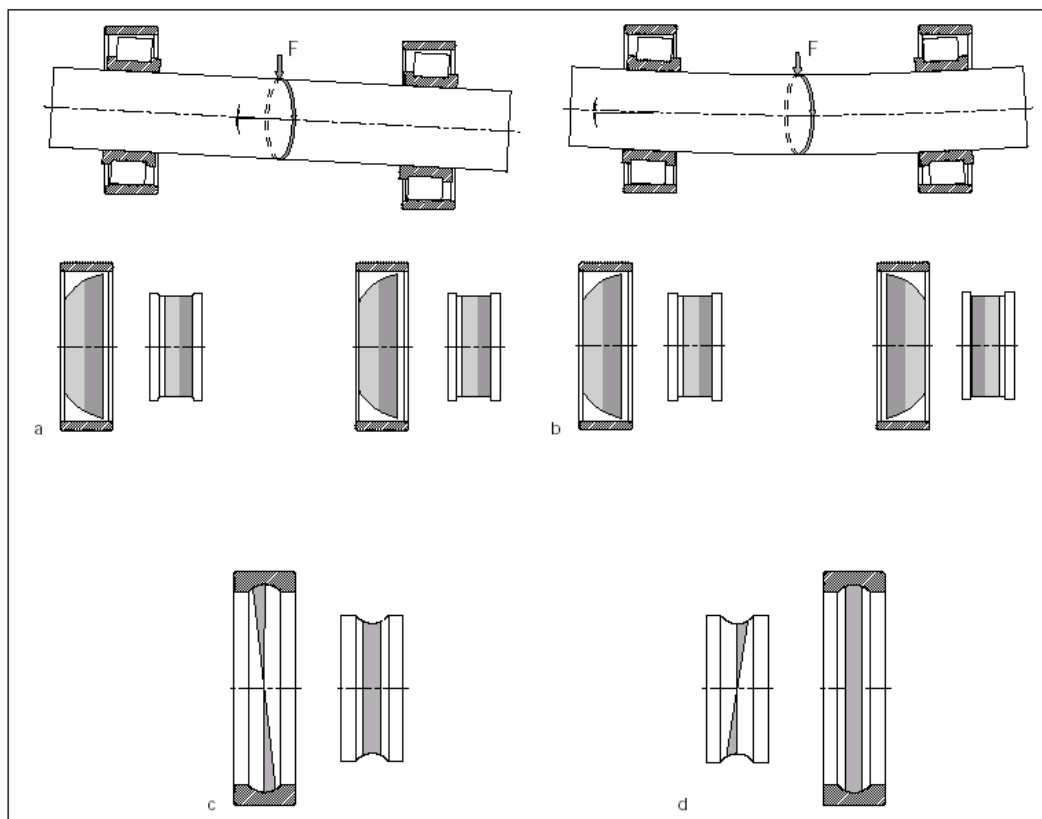

Figure 9: Oblique track in inner ring of deep groove ball bearing



## Rolling Bearing Failure Analysis

---

### 2.1.8 Fatigue of rolling bearings due to misalignment

Symptoms:

- ✓ Material flaking (relatively deep)
- ✓ Tracking asymmetric to bearing centre
- ✓ Fatigue damage on the edges of raceway and/ or rolling elements

Causes:

- ✓ Misalignment of the housing or shaft, bending or tilting loads
- ✓ Balls running on the shoulder edge

Possible remedies:

- ✓ Use self-aligning bearings
- ✓ Correct misalignment
- ✓ Strengthen shaft

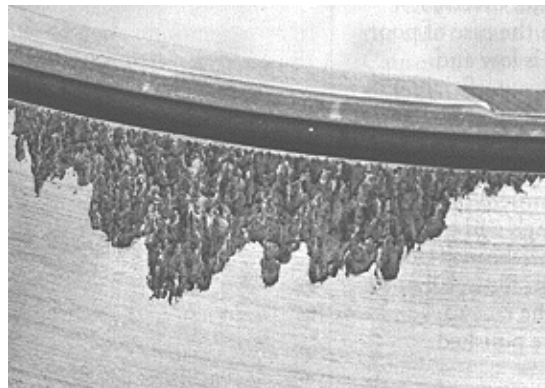

*Figure 10: Fatigue may occur at the edge of the raceway of a misaligned tapered roller bearing due to local overload.*

## Rolling Bearing Failure Analysis

### 2.1.9 Fatigue as a result of poor lubrication

Symptoms:

Diverse damage patterns arise

- ✓ Tiny superficial fractures and pitting develops

Causes:

- ✓ Poor lubrication condition as a result of insufficient lubricant supply
- ✓ Operating temperature too high
- ✓ Water penetration
- ✓ Very low or high loads on the raceways
- ✓ Slippage at times

Possible remedies:

- ✓ Increase lubricant quantity
- ✓ Use lubricant with a higher viscosity, if possible with tested Extreme Pressure (EP) additives
- ✓ Cool lubricant/ bearing position
- ✓ Use softer grease perhaps
- ✓ Prevent water penetration

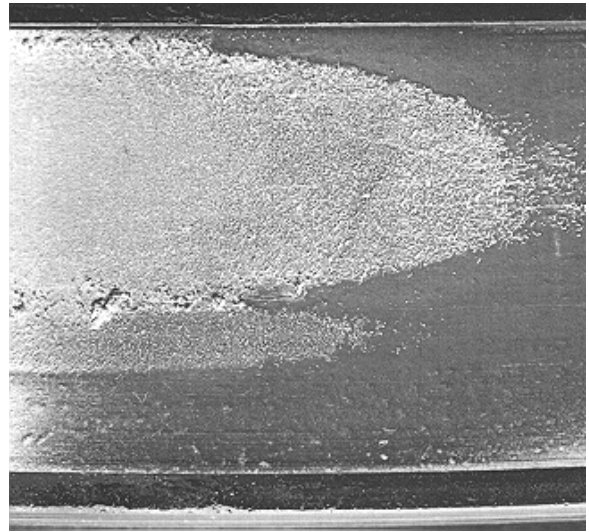

Figure 11: Micro Pitting

## Rolling Bearing Failure Analysis

### 2.1.10 Corrosion

Corrosion in rolling bearings may occur in various forms and have different causes. The damage shows up as uneven and loud running noise. Corrosion (dark grey stains and pitting) will ultimately cause wear and spalling.

#### Symptoms:

- ✓ Brownish discoloration of the complete bearing surface, usually unevenly distributed in the form of individual pits
- ✓ Spots of rust with pits
- ✓ Wear at a later stage and premature fatigue originating at the rust pits

#### Causes:

- ✓ Inadequate sealing against moisture,
- ✓ acid fumes,
- ✓ lubricants containing acids,
- ✓ condensation,
- ✓ unsuitable storage of the rolling bearings in the warehouse.

#### Possible remedies:

- ✓ Suitable storage according to the specifications of rolling bearing manufacturer
- ✓ Improvement in seals (additional shields perhaps)
- ✓ Use lubricant with corrosion inhibitors
- ✓ Re-lubricate frequently in the case of grease lubrication, particularly prior to standstill periods

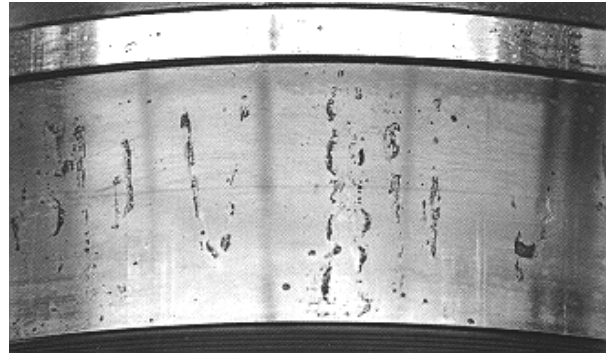

Figure 12: 'Etched' surfaces are caused by aggressive media.

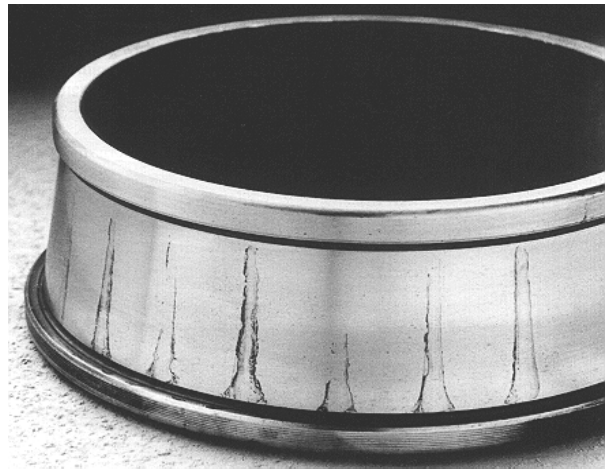

Figure 13: Surface damage due to attack of aggressive media. The etching pits are usually black

## Rolling Bearing Failure Analysis

### 2.1.11 False Brinelling

#### Symptoms:

- ✓ Shiny marks and recesses on the raceway surface at the rolling element pitch
- ✓ No raised edges as opposed to marks due to incorrect mounting
- ✓ Scratches in the axial direction

#### Causes:

- ✓ Vibrations in stationary machines – leads to micro-motion in the contact areas

#### Possible remedies:

- ✓ Eliminate or absorb vibrations
- ✓ Use locking devices to prevent possible movement during transportation
- ✓ Slowly rotate bearings and shaft when not in service

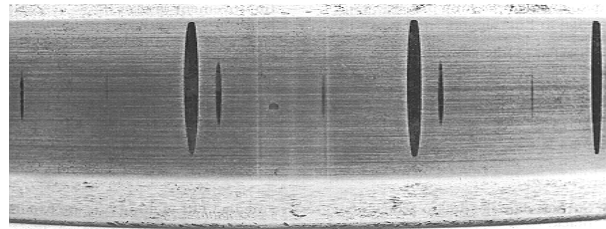

Figure 14: On the inner ring of a cylindrical roller bearing, marks due to false brinelling have developed on the raceway at rolling element pitch



Figure 15: False brinelling marks on the inner ring of an angular contact ball bearing

## Rolling Bearing Failure Analysis

### 2.1.12 Passage of Electric Current

#### Electrical Fluting

Symptoms:

- ✓ Brownish marks parallel to the axis on a large part of the raceway or covering the entire raceway circumference

Causes:

- ✓ Constant passage of alternating or direct current, even low currents cause marks

Possible remedies:

- ✓ Prevent currents from flowing through the bearing (earthing, insulation)
- ✓ Use current insulated bearings



*Figure 17: Fluting in the inner ring raceway of a tapered roller bearing was caused by the constant passage of current*

#### Fusion Crater

Symptoms:

- ✓ The surface in the fusion craters is partly formed like welding beads.

Causes:

- ✓ Welding or poor earth contact

Remedial measures:

- ✓ Do not direct current through bearing during electro welding
- ✓ Attached additional earth connections.



*Figure 18: Fusion Crater on the inner ring raceway of a cylindrical roller bearing due to welding*

## Rolling Bearing Failure Analysis

### 2.1.13 Ring fractures

#### Axial cracks and completely cracked inner rings

Symptoms:

- ✓ Ring partly or completely cracked in the axial direction
- ✓ Sharp-edged crack flanks indicate that fracture occurred during dismounting
- ✓ In case of long term operation the edges of the cracks may be broken off

Causes:

- ✓ Bearing slippage
- ✓ Fractures in the raceway
- ✓ Rotation of outer ring on the shaft
- ✓ Unsuitable lubrication
- ✓ Fit too tight on the shaft
- ✓ Keyway or grooves in load zone
- ✓ Out-of-roundness
- ✓ Grazing against surrounding parts

Possible remedies:

- ✓ Improve lubrication (additives, increase oil quantity)
- ✓ Find remedial measures for damage to raceway
- ✓ Select suitable fit
- ✓ Avoid grazing with surrounding parts
- ✓ Provide better seating conditions for the bearing (fits and surface finish)
- ✓ Special heat treatment for rings (Casehardening)



*Figure 19: Cracked inner ring of a spherical roller bearing*

## Rolling Bearing Failure Analysis

### Outer ring fractures in circumferential direction

#### Symptoms:

- ✓ Cracks evenly in the circumferential direction
- ✓ With axial load, the fractures occur as a rule beyond the middle of the raceway
- ✓ Fatigue damage

#### Causes:

- ✓ Poor support of the rings in the housing

#### Possible remedies:

- ✓ Constructive improvement in mounting required

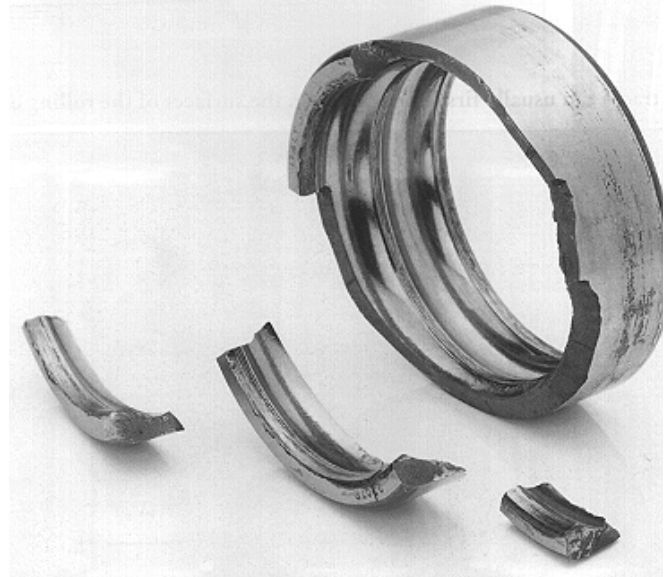

Figure 20: Cracked outer ring in circumferential direction

### Inner ring fractured lip

#### Symptoms:

- ✓ Lip fractured.

#### Causes:

- ✓ Unsuitable design
- ✓ Inaccurate machining
- ✓ High axial loading

#### Remedial measures:

Change mating parts construction

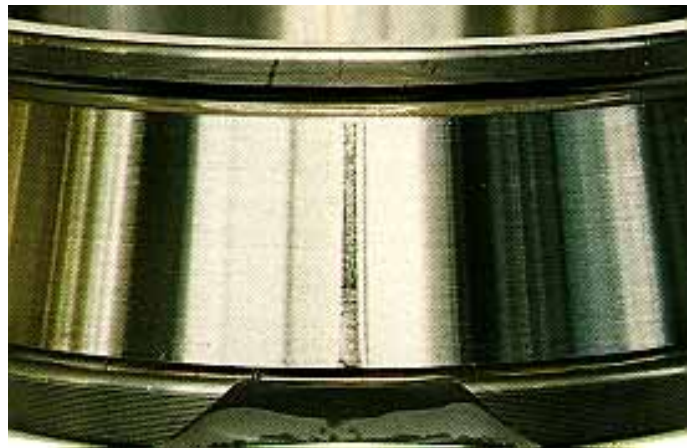

Figure 21: Fractured lip on the back lip of the tapered roller bearing



## Rolling Bearing Failure Analysis

### 2.1.14 Slippage tracks

Symptoms:

- ✓ Rolling element sliding, particularly in the case of large and heavy rollers e.g. in cageless bearings.
- ✓ Material often rolled up with smear marks

Causes:

- ✓ Rolling elements slide on the raceways when load is low and lubrication is poor.
- ✓ Excessive bearing clearances (small load zone) and light loads
- ✓ Fast changes in speed with light loads

Possible remedies:

- ✓ Use bearings with lower load carrying capacity
- ✓ Preload bearings, e.g. with springs
- ✓ Reduce bearing clearance
- ✓ Ensure sufficient load during the trial run also
- ✓ Improve lubrication

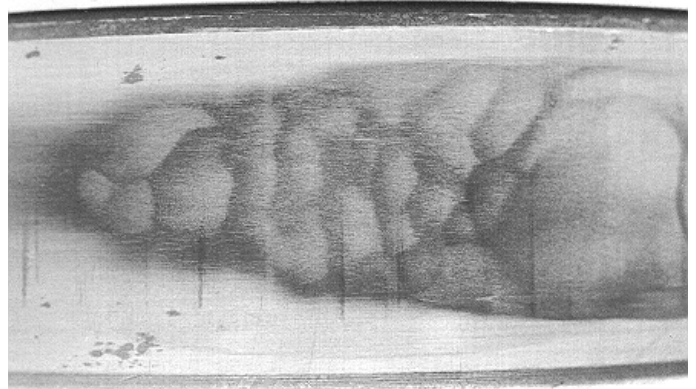

Figure 22: Slippage damage on the inner ring of a cylindrical roller bearing

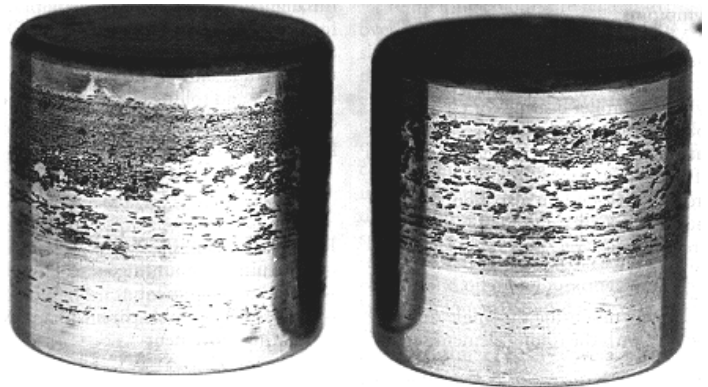

Figure 23: Slippage tracks on cylindrical rollers

## Rolling Bearing Failure Analysis

---

### 2.1.15 Score marks

Symptoms:

- ✓ Score marks at rolling element spacing on the raceways of cylindrical roller bearings and tapered roller bearings.
- ✓ Markings are displaced to one another by a few degrees around the raceway circumference
- ✓ Frequently found on just about 1/3 of the raceway circumference

Causes:

- ✓ Poor alignment of the rolling elements during mounting
- ✓ Forced together when not aligned

Possible remedies:

- ✓ Use suitable mounting aids
- ✓ Avoid misalignment
- ✓ Assemble parts with a slow rotating movement, if possible



*Figure 24: Score marks in the raceway of a cylindrical roller bearing inner ring caused by out-of-square insertion into the rolling element set*

## Rolling Bearing Failure Analysis

### 2.1.16 Damage due to overheating

#### Symptoms:

- ✓ Bearing parts badly discoloured (brown and blue shades due to extremely high operating temperatures)
- ✓ Deformed to a large extent

#### Causes:

- ✓ Bearing clearance in operating condition too low, especially with high speed bearings
- ✓ Inadequate lubrication
- ✓ Radial preload due to external heating
- ✓ Over-lubrication
- ✓ Impeded running due to cage fracture

#### Possible remedies:

- ✓ Increase bearing clearance
- ✓ In case of external heating, increase heating times and cooling down time, to allow uniform heat distribution of complete bearing assembly
- ✓ Avoid excessive lubricant build-up
- ✓ Improve lubrication



*Figure 25: Colour changes and deformations of the raceway due to extreme temperatures*

## Rolling Bearing Failure Analysis

### 2.1.17 Assessment of lip contact

#### Scoring due to foreign particles

Symptoms:

- ✓ Arc-shaped scratches on the lip surface in cylindrical and tapered roller bearings

Causes:

- ✓ Hard foreign particles in lubricant which are drawn into the area of contact between roller face and lip

Possible remedies:

- ✓ Improve lubricant cleanliness

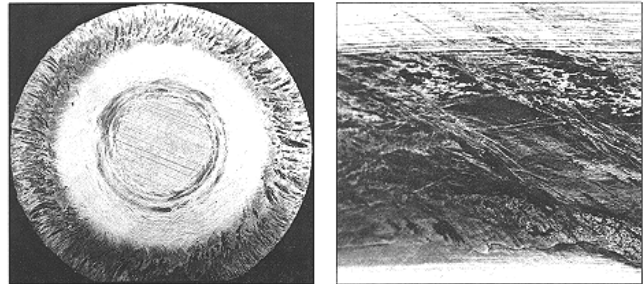

Figure 26: Seizure can arise at the roller face and lip when the lubricant supply is inadequate and loads are high.

#### Seizure of lip contact

Symptoms:

- ✓ Partial or large-area welding and deep scratches in the lip and the roller face areas
- ✓ Frequently related to very high loads

Causes:

- ✓ Inadequate lubrication at high loads and high speeds
- ✓ Inadequate lubrication with high loads and low speeds
- ✓ Too high preload of tapered roller bearings
- ✓ Detrimental preload due to heat expansion
- ✓ Insufficient adjustment
- ✓ Axial load too high on cylindrical roller bearings

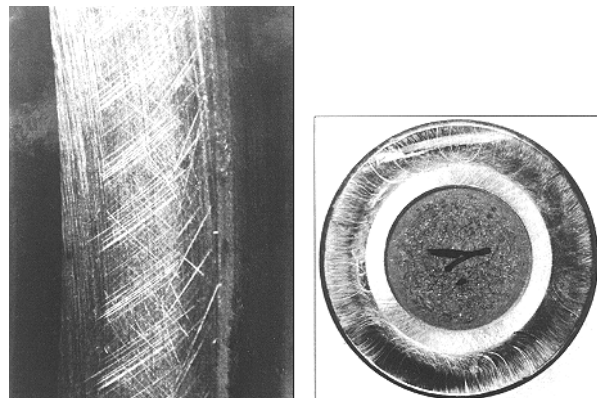

Figure 27: Scoring due to foreign particles (left) and scoring on the end of a tapered roller (right)

Possible remedies:

- ✓ Improve lubrication (increase viscosity, EP additives, increase lubricant quantity)
- ✓ Ensure correct adjustment of bearings

## Rolling Bearing Failure Analysis

### 2.2 Damage relating to bearing cages

#### 2.2.1 Cage wear due to starved lubrication and contamination

Symptoms:

- ✓ Wear in the pockets
- ✓ Poor rolling element guidance due to wear

Causes:

- ✓ Lubricant contaminated with hard foreign particles
- ✓ Too little or unsuitable lubricant

Possible remedies:

- ✓ Ensure clean assembly conditions
- ✓ Filter lubricant
- ✓ Increase lubricant flow through and/ or apply a different viscosity



*Figure 28: Cage split in half due to lubrication starvation at high speed*

#### 2.2.2 Wear due to excess speed

Symptoms:

- ✓ Excessive wear between the guidance surfaces of the cage

Causes:

- ✓ Excess speed
- ✓ Unsuitable cage construction selected

Possible remedies:

- ✓ Use different type of cage

## Rolling Bearing Failure Analysis

### 2.2.3 Wear due to roller skewing

Symptoms:

- ✓ Roller skewing results when roller bearings carry low loads or when badly tilt or when tapered roller bearings are not sufficiently adjusted
- ✓ If the skewing forces cannot be accommodated by the lips, wear areas, which are diagonally opposite one another, develop due to the high load in the cage pockets.

Causes:

- ✓ Tilting of the bearings, partly due to misalignment
- ✓ Faulty adjustment of clearance in the bearings

Possible remedies:

- ✓ Adjust bearings correctly
- ✓ Use self-aligning bearings, avoid misalignment

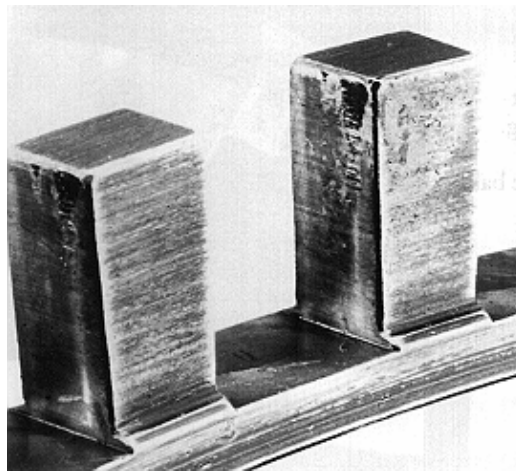

Figure 29: Diagonal wear in cage pockets of roller bearings

## Rolling Bearing Failure Analysis

### 2.2.4 Wear in ball bearing cages due to tilting

Symptoms:

- ✓ Deformation or fracture of the cage could occur

Causes:

- ✓ Excess misalignment of the bearing rings to one another.
- ✓ High acceleration forces
- ✓ Stress in cage area high, especially with poor lubrication

Possible remedies:

- ✓ Avoid tilting as much as possible
- ✓ Select self-aligning bearings or bearings with polyamide cages
- ✓ Special design: long hole pockets

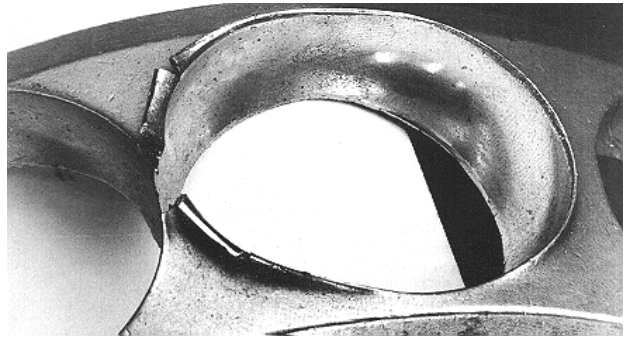

*Figure 30: Bearing rings tilting towards one another led to high constraining forces between balls and cage which, in turn, led to web fracture.*

## Rolling Bearing Failure Analysis

### 2.2.5 Cage fracture

Symptoms:

- ✓ Fracture of cage side edges, crosspiece fracture more seldom

Causes:

- ✓ Mounting damage
- ✓ Exceeded the permissible speed
- ✓ Poor lubrication
- ✓ Moment load too high or tilting of ball bearings
- ✓ Tapered roller bearing pairs with excessive clearance, or when axial loads reverse quickly

Possible remedies:

- ✓ Mount carefully
- ✓ Filter lubricant
- ✓ Increase lubricant flow through and/ or different viscosity
- ✓ Avoid misalignment or shaft deflection
- ✓ Reduce bearing clearances

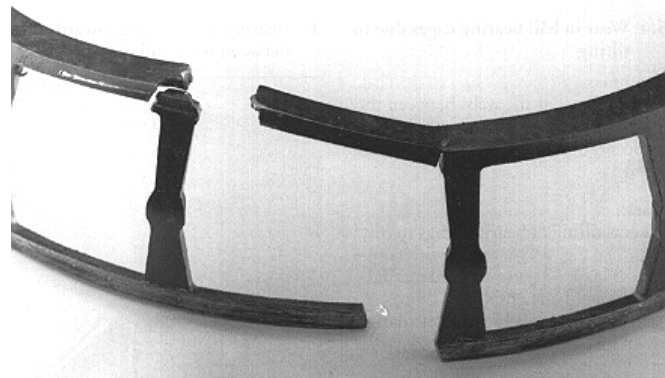

Figure 31: Fractured corner edge of the cage

### 2.2.6 Damage due to incorrect mounting

Symptoms:

- ✓ Broken, melted, cracked plastic cages and bent or warped metal cages

Causes:

- ✓ Incorrect heating of the bearing for mounting
- ✓ Unsuitable mounting tools

Possible remedies:

- ✓ Mount according to manufacturer's specifications





